

Dual N-Channel 20-V (D-S) MOSFET

These miniature surface mount MOSFETs utilize a high cell density trench process to provide low $r_{DS(on)}$ and to ensure minimal power loss and heat dissipation. Typical applications are DC-DC converters and power management in portable and battery-powered products such as computers, printers, PCMCIA cards, cellular and cordless telephones.

- Low $r_{DS(on)}$ provides higher efficiency and extends battery life
- Low thermal impedance copper leadframe SOIC-8PP saves board space
- Fast switching speed
- High performance trench technology

PRODUCT SUMMARY		
V_{DS} (V)	$r_{DS(on)}$ m(Ω)	I_D (A)
20	10 @ $V_{GS} = 4.5V$	33
	13 @ $V_{GS} = 2.5V$	29

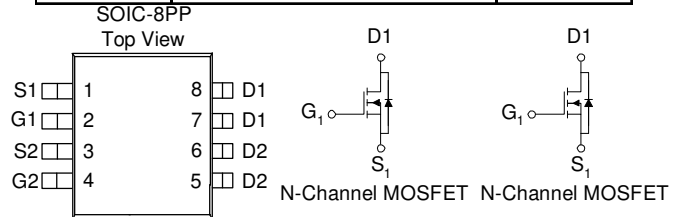

RoHS
COMPLIANT
HALOGEN
FREE

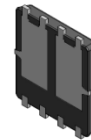

ABSOLUTE MAXIMUM RATINGS ($T_A = 25^\circ C$ UNLESS OTHERWISE NOTED)			
Parameter	Symbol	Limit	Units
Drain-Source Voltage	V_{DS}	20	V
Gate-Source Voltage	V_{GS}	8	
Continuous Drain Current ^a	I_D	$T_A=25^\circ C$	33
		$T_A=70^\circ C$	27
Pulsed Drain Current ^b	I_{DM}	± 50	A
Continuous Source Current (Diode Conduction) ^a	I_S	13	A
Power Dissipation ^a	P_D	$T_A=25^\circ C$	16
		$T_A=70^\circ C$	10
Operating Junction and Storage Temperature Range	T_J, T_{stg}	-55 to 150	$^\circ C$

THERMAL RESISTANCE RATINGS				
Parameter	Symbol	Maximum	Units	
Maximum Junction-to-Ambient ^a	$t \leq 10$ sec	$R_{\theta JA}$	35	
	Steady State	$R_{\theta JC}$	8	

Notes

- a. Surface Mounted on 1" x 1" FR4 Board.
- b. Pulse width limited by maximum junction temperature

SPECIFICATIONS ($T_A = 25^{\circ}\text{C}$ UNLESS OTHERWISE NOTED)						
Parameter	Symbol	Test Conditions	Limits			Unit
			Min	Typ	Max	
Static						
Gate-Threshold Voltage	$V_{GS(th)}$	$V_{GS} = V_{DS}$, $I_D = 250\ \mu\text{A}$	1			V
Gate-Body Leakage	I_{GSS}	$V_{GS} = 8\ \text{V}$, $V_{DS} = 0\ \text{V}$			± 100	nA
Zero Gate Voltage Drain Current	I_{DSS}	$V_{DS} = 16\ \text{V}$, $V_{GS} = 0\ \text{V}$			1	μA
On-State Drain Current ^A	$I_{D(on)}$	$V_{DS} = 5\ \text{V}$, $V_{GS} = 10\ \text{V}$	20			A
Drain-Source On-Resistance ^A	$r_{DS(on)}$	$V_{GS} = 4.5\ \text{V}$, $I_D = 1\ \text{A}$			10	m Ω
		$V_{GS} = 2.5\ \text{V}$, $I_D = 1\ \text{A}$			13	
Forward Transconductance ^A	g_{fs}	$V_{DS} = 15\ \text{V}$, $I_D = 1\ \text{A}$		40		S
Dynamic						
Total Gate Charge	Q_g	N-Channel $V_{DS}=15\text{V}$, $V_{GS}=4.5\text{V}$, $I_D=1\text{A}$		30		nC
Gate-Source Charge	Q_{gs}			5		
Gate-Drain Charge	Q_{gd}			10		
Input Capacitance	C_{iss}	N-Channel $V_{DS}=15\text{V}$, $V_{GS}=0\text{V}$, $f=1\text{MHz}$		3000		pF
Output Capacitance	C_{oss}			300		
Reverse Transfer Capacitance	C_{rss}			200		
Turn-On Delay Time	$t_{d(on)}$	N-Channel $V_{DD}=15\text{V}$, $V_{GS}=10\text{V}$, $I_D=1\text{A}$, $R_{GEN}=25\Omega$		10		nS
Rise Time	t_r			20		
Turn-Off Delay Time	$t_{d(off)}$			60		
Fall-Time	t_f			10		

Notes

- Pulse test: $PW \leq 300\ \mu\text{s}$ duty cycle $\leq 2\%$.
- Guaranteed by design, not subject to production testing.

Analog Power (APL) reserves the right to make changes without further notice to any products herein. APL makes no warranty, representation or guarantee regarding the suitability of its products for any particular purpose, nor does APL assume any liability arising out of the application or use of any product or circuit, and specifically disclaims any and all liability, including without limitation special, consequential or incidental damages. "Typical" parameters which may be provided in APL data sheets and/or specifications can and do vary in different applications and actual performance may vary over time. All operating parameters, including "Typicals" must be validated for each customer application by customer's technical experts. APL does not convey any license under its patent rights nor the rights of others. APL products are not designed, intended, or authorized for use as components in systems intended for surgical implant into the body, or other applications intended to support or sustain life, or for any other application in which the failure of the APL product could create a situation where personal injury or death may occur. Should Buyer purchase or use APL products for any such unintended or unauthorized application, Buyer shall indemnify and hold APL and its officers, employees, subsidiaries, affiliates, and distributors harmless against all claims, costs, damages, and expenses, and reasonable attorney fees arising out of, directly or indirectly, any claim of personal injury or death associated with such unintended or unauthorized use, even if such claim alleges that APL was negligent regarding the design or manufacture of the part. APL is an Equal Opportunity/Affirmative Action Employer.

Package Information

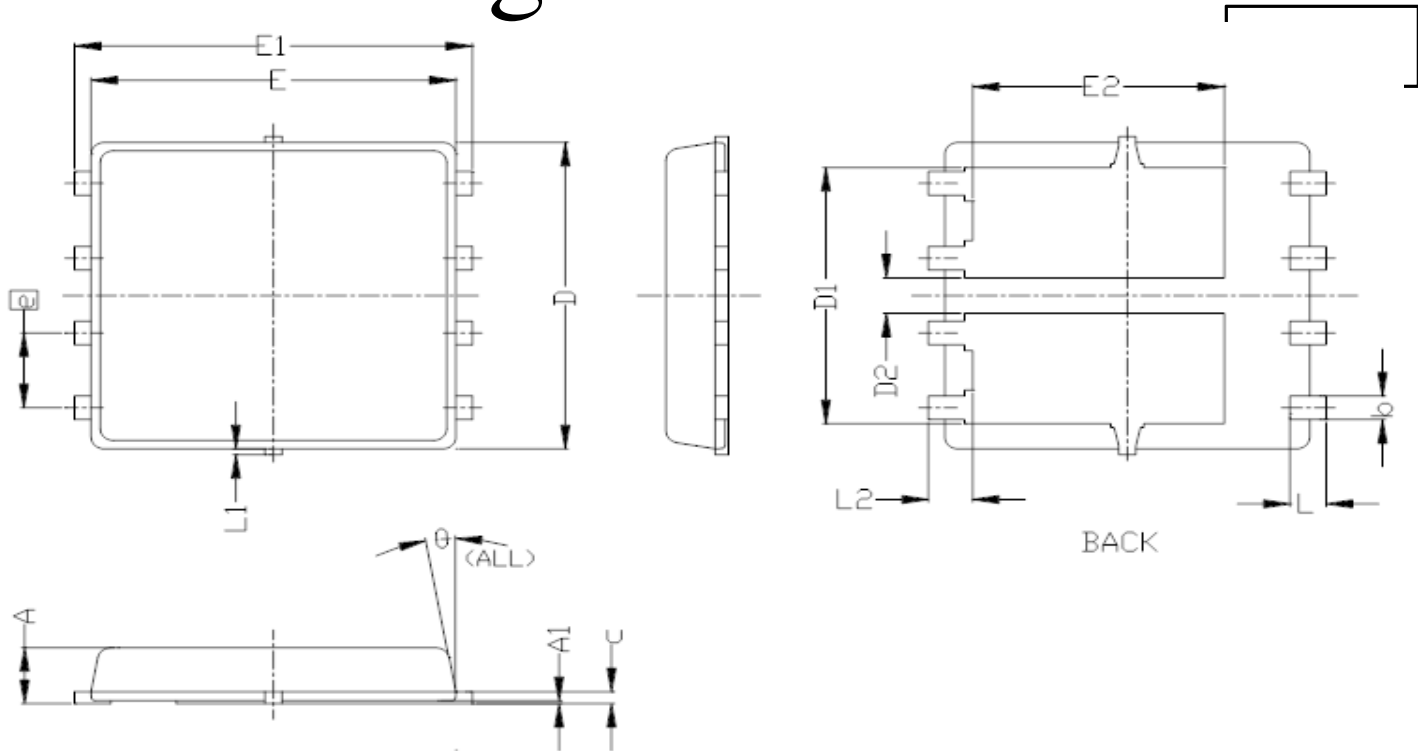

SYMBOLS	DIMENSIONS IN MILLIMETERS			DIMENSIONS IN INCHES		
	MIN	NOM	MAX	MIN	NOM	MAX
A	0.85	0.95	1.00	0.033	0.037	0.039
A1	0.00	—	0.05	0.000	—	0.002
b	0.30	0.40	0.50	0.012	0.016	0.020
c	0.15	0.20	0.25	0.006	0.008	0.010
D	5.20 BSC			0.205 BSC		
D1	4.35 BSC			0.171 BSC		
D2	0.50	0.60	0.75	0.020	0.024	0.030
E	5.55 BSC			0.219 BSC		
E1	6.05 BSC			0.238 BSC		
E2	3.82 BSC			0.150 BSC		
e	1.27 BSC			0.050 BSC		
L	0.45	0.55	0.65	0.018	0.022	0.026
L1	0	—	0.15	0	—	0.006
L2	0.68 REF			0.027 REF		
θ	0°	—	10°	0°	—	10°